



# Contributing to profitable farming

[www.shell.com/lubricants](http://www.shell.com/lubricants)

## WORKS HERE.







## MAXIMISING MACHINE AVAILABILITY

Poor lubricants and lubrication practices can mean equipment downtime. In the agricultural industry, machines with operational reliability are critical to a good harvest.

By working with Shell Lubricants you may be able to reduce your process and equipment-ownership costs by using toptier oils that are designed to provide

- **enhanced protection**
- **reduced lubricant consumption**
- **improved efficiency.**

### REDUCED MAINTENANCE

In the rice-exporting region of Gujranwala, Pakistan, the 200+ harvester owners have only a single measure of lubricant quality for their \$20,000–40,000 equipment: the oil's ability to maintain compression pressure in the engine. Failure of compression pressure due to engine oil quality means prolonged downtimes for equipment. When using Shell Rimula diesel engine oil, the engines maintained compression pressure better and the owners reported a **75%<sup>1</sup> reduction in downtime** in their reconditioned and used machinery.

Maintenance costs **went down by 60%** as a consequence. Shell VideoCheck and Shell LubeAnalyst services were used to demonstrate Shell Rimula's superiority over the previously used lubricant.

<sup>1</sup>The savings indicated are specific to the calculation date and mentioned site. These calculations may vary from site to site and from time to time, depending, for example, on the application, the operating conditions, the current products being used, the condition of the equipment and the maintenance practices.

### ENHANCED PROTECTION

Shell Rimula diesel engine oils offer protection in the three critical areas that put the most stress on machines.

**Wear.** The failure of an engine oil to protect moving parts from friction can lead to overheating and wear. The anti-wear molecules in Shell Rimula oils form a protective lubricating film at high-stress points that protects metal surfaces from friction and thereby prevents wear.

**Deposits.** Excessive piston deposits can cause cylinder wear and piston seizure. This shortens engine life and increases oil consumption. Shell Rimula oils contain active molecules that loosen particle bonds and thus prevent deposits from forming.

**Corrosion.** Acids formed during diesel combustion can get into the oil and corrode bearings, which can lead to engine failure. Shell Rimula oils contain high-performance neutralisers that protect the engine from these acids.

SHELL'S LUBRICANTS  
PROTECT YOUR  
WARRANTY  
AGREEMENTS  
BY MEETING  
EQUIPMENT-  
MANUFACTURERS'  
AND INDUSTRY  
SPECIFICATIONS



Shell Rimula R5 LE 10W-40  
Shell Rimula R4 X 15W-40

Shell Spirax S4 TXM 10W-30\*

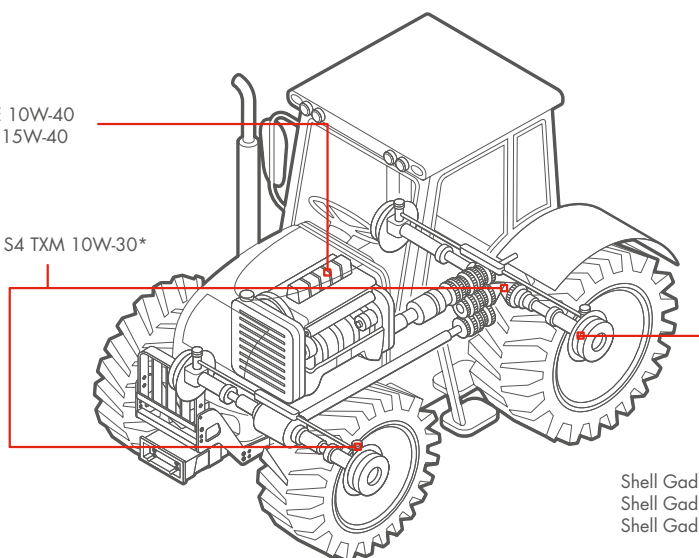

Shell Gadus S3 V220C 2  
Shell Gadus S2 V220AC 2  
Shell Gadus S2 V220 2

\*Shell Spirax S4 TXM is a universal tractor transmission oil (UTTO) that can also be used for hydraulic and immersed wet brake systems.

### FULL PRODUCT PORTFOLIO

MACHINERY APPLICATION	MAINLINE	PREMIUM	ADVANCED
ENGINES (TRACTORS AND HARVESTERS)	Shell Rimula R2 Multi	Shell Rimula R4 X	Shell Rimula R5 LE
TRACTOR TRANSMISSIONS	Shell Spirax S2 T Shell Spirax S2 TQ	Shell Spirax S4 TXM	Shell Spirax S6 TXME
HYDRAULICS (HARVESTERS)	Shell Tellus S2 M 68 Shell Spirax S2 T/TQ	Shell Tellus S2 V 46 Shell Spirax S4 TXM	Shell Tellus S3 V 46 Shell Spirax S6 TXME
FRONT-WHEEL-DRIVE AXLES (TRACTORS) AND HARVESTER AXLES	Shell Spirax S2 ALS 90	Shell Spirax S3 ALS 80W-90	
GREASES	Shell Gadus S2 V220	Shell Gadus S2 V220AC	Shell Gadus S3 V220C



## WORKING WITH INDUSTRY

Today's sophisticated, high-powered machinery operating at maximum load puts additional demands on lubricants. To respond to market needs, Shell is continually developing its products to help you reduce operating costs and keep your agricultural equipment working efficiently.

FROM HEAVY-DUTY ENGINE OILS TO SPECIALIST FINAL-DRIVE LUBRICANTS, SHELL SUPPLIES A WIDE RANGE OF INNOVATIVE PRODUCTS AND SUPPORTING SERVICES BACKED UP BY INTERNATIONAL EXPERTISE.

## WORLD-LEADING SERVICES

Shell Lubricants is the world's number-one lubricants supplier<sup>1</sup> and provides support to customers in over 100 countries. We offer a powerful combination of highly responsive local service and expertise from an international network of research and development centres, manufacturing and blending plants and distribution facilities.

We are committed to developing the world's best lubricant technologies and invest significantly in the research and development of new products. Shell also offers the most comprehensive range of lubricant value added services, through the largest technical delivery team within the industry. Our services – Shell LubeAnalyst, Shell LubeAdvisor, Shell LubeCoach and Shell LubeMatch – are designed to help customers choose and use the right lubricants and improve the operations.

Shell  
LubeAnalyst

Shell  
LubeAdvisor

Shell  
LubeCoach

Shell  
LubeMatch

<sup>1</sup>Global Lubricants 2013: Market Analysis and Assessment, Kline and Company



Find out more by visiting  
[www.shell.com/lubricants](http://www.shell.com/lubricants)

